

Donaldson.  
Torit®

**WSO MIST  
COLLECTORS**



**Synteq XP™**  
MEDIA TECHNOLOGY  
FOR MIST COLLECTION



## THE ONLY MIST COLLECTOR YOU NEED

The versatile Donaldson® Torit® WSO Mist Collector provides three filter solutions for water-soluble coolant, straight oil, and the most challenging, oily smoke. The WSO uses revolutionary Synteq XP™ Media Technology engineered for superior draining, resulting in lower pressure drop and longer filter life.

The WSO can be modified with a simple filter change, leading to leaner operation, cost savings and cleaner plant air.

### WSO Offers:

- **3 in 1 solutions for mist applications**
- **Advanced Synteq XP™ high efficiency media**
- **Cross-flow design for better drainage**
- **Easy to change cartridge filters**
- **Energy savings**
- **Continuous-duty design**
- **Lower life cycle costs**
- **Quiet operation**
- **Configurations for machine mounting, floor stands, or ducted central systems**
- **UL-approved electrical components**
- **10-year warranty**

**3** APPLICATIONS  
**1** COLLECTOR



**3** SOLUTIONS



**WSO 15**  
with optional  
3rd-stage HEPA filter

THE WSO DIFFERENCE

The WSO mist collector can be configured to meet your facility's requirements: machine mountable, floor-mounted stand, and ducted cellular and central systems.

OVER **40** YEARS OF MIST EXPERIENCE

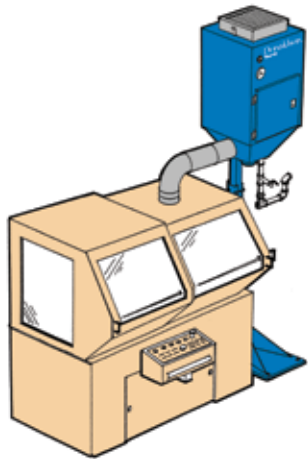

**WSO 15**  
floor-mounted stand with afterfilter on a horizontal machining center.

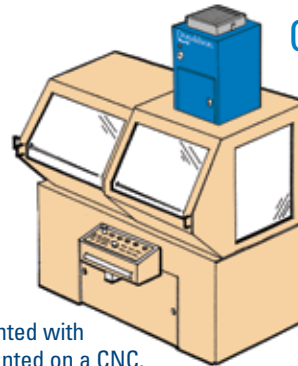

**WSO 10**  
machine mounted with afterfilter mounted on a CNC.

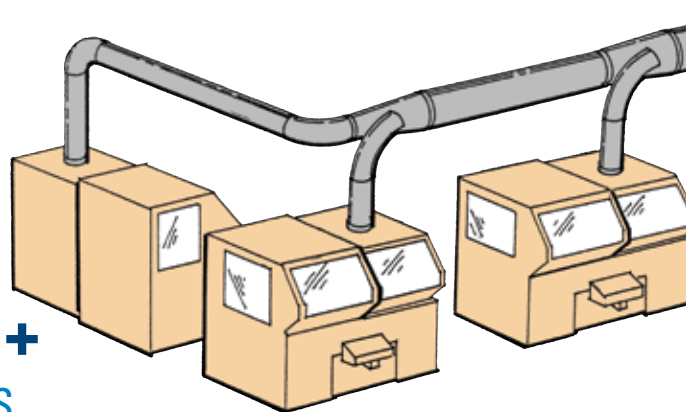

**WSO 20**  
with afterfilter ducted to a machining center.

**75,000+**  
MIST COLLECTORS  
INSTALLED

EASY FILTER MAINTENANCE



Differential pressure gauge(s) identifies filter maintenance.



One pivot lever securely retains the primary filter element.



Filter is easily removed.



Simplified servicing means less maintenance time and cost.

VERSATILE IN APPLICATION, FLEXIBLE IN DESIGN

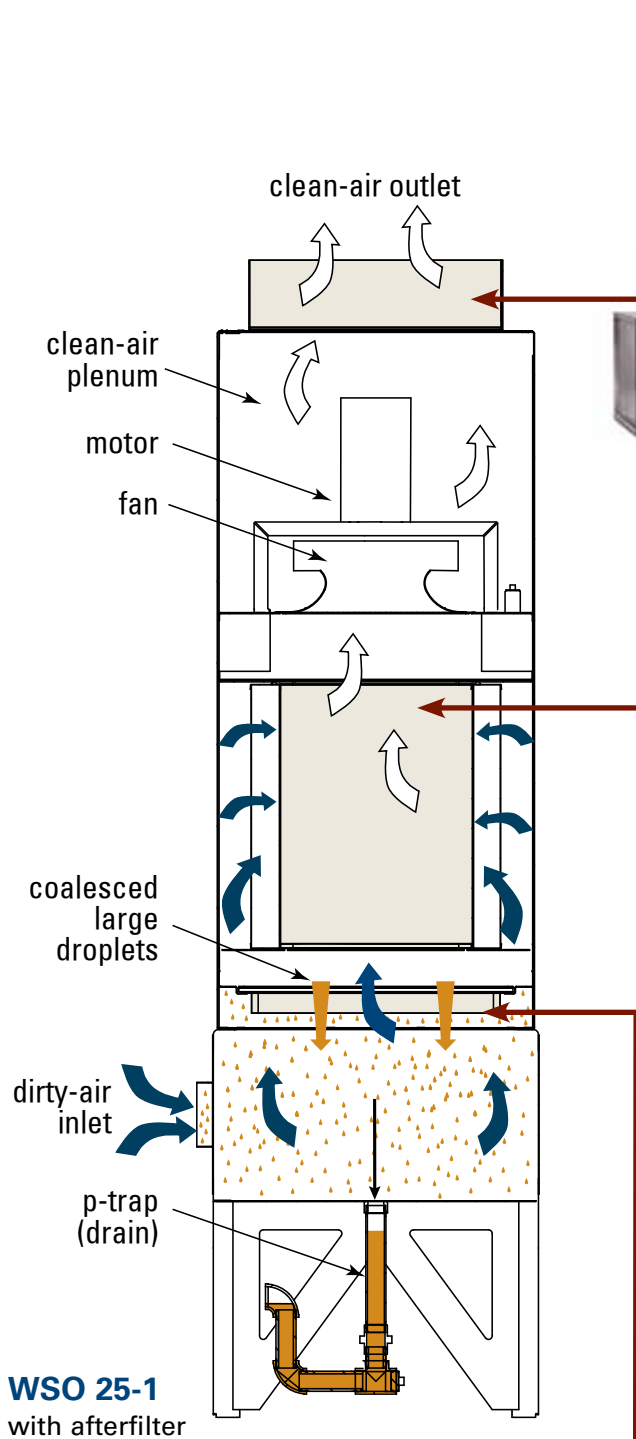

**3RD STAGE:  
FINAL FILTER (OPTIONAL)**

- DOP  
95% efficient on 0.3 micron mist & smoke
- HEPA  
99.97% efficient on 0.3 micron mist & smoke



**2ND STAGE:  
PRIMARY FILTER  
(SELECT ONE)**



- SYNTEQ XP - W
  - For mist from water-soluble coolant
  - Economical, fast draining, for heavy water-based liquid load
- SYNTEQ XP - S
  - For smoke from machining
  - Highest efficiency for challenging applications
- SYNTEQ XP - O
  - For mist from straight oil machining
  - Efficiency designed for small oil aerosols

**1ST STAGE:  
PREFILTER OPTIONS (SELECT ONE)**

- METAL SCREEN  
For heavier dust/grit from wet grinding
- METAL MESH  
For most water-soluble mist
- POLYPROPYLENE MESH  
For most straight oil mist
- HIGH EFFICIENCY 1ST STAGE  
For oily smoke



**OBLONG CARTRIDGES OUTPERFORM TRADITIONAL FILTERS**



**WSO OBLONG FILTER SHAPE FEATURES:**

- Up to 45% more filter surface area than pocket filters and round cartridges
- Best fit in rectangular cabinet
- Lower pressure drop
- Longer filter life

**CROSS-FLOW FILTER DESIGN**

Cross-flow filter design for better drainage means longer filter life. Dirty air flows horizontally through the walls of the WSO filter, perpendicular to drainage of collected and coalesced mist. This design promotes optimum drainage, which extends filter life and returns collected coolant for re-use. Conventional mist collectors have an upflow design impeding drainage and causing short filter life.

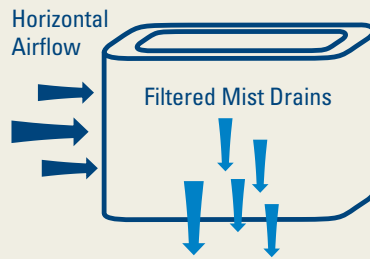

**WSO Cross-Flow Filter**

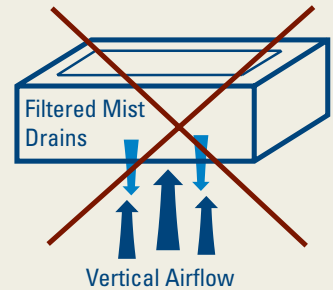

**Up-Flow Filter**

**CHOOSE THE BEST FILTER FOR YOUR APPLICATION**



**WATER SOLUBLE**

Typical particle size: 2-20 micron

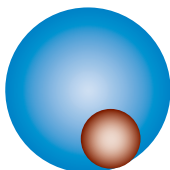

- Largest mist particles
- 99.8%\* removal efficiency



**SMOKE**

Typical particle size: 0.07-1.2 micron



- Smallest aerosols from machining
- 99.97%\*\* removal efficiency



**OIL**

Typical particle size: 0.8-5 micron

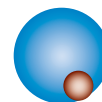

- Submicron oil mist
- 99.5%\* removal efficiency

\* Stated efficiency typical for water-soluble and straight oil applications. The use of 95% DOP or HEPA filter may be required.  
 \*\* Stated efficiency typical for oily smoke application using a HEPA final filter

**ADVANCED FILTER MEDIA FOR MIST**

Proprietary Synteq XP Media Technology is a revolutionary new media for mist collection that provides high efficiency, low operating pressure drop, and long filter life when compared to traditional media.

This photo from our Scanning Electron Microscope and the illustration show why Synteq XP Media Technology provides superior performance on mist collection applications.

**SYNTEQ XP MEDIA TECHNOLOGY WITH RESIN-FREE, BINDING FIBERS**

- Engineered blend of small and large fibers, with proprietary, resin-free bonding system
- Small fibers are scientifically proven to increase efficiency
- Large fibers provide structural support and clear drain channels
- Proprietary bonding system stabilizes pore structure for optimum performance

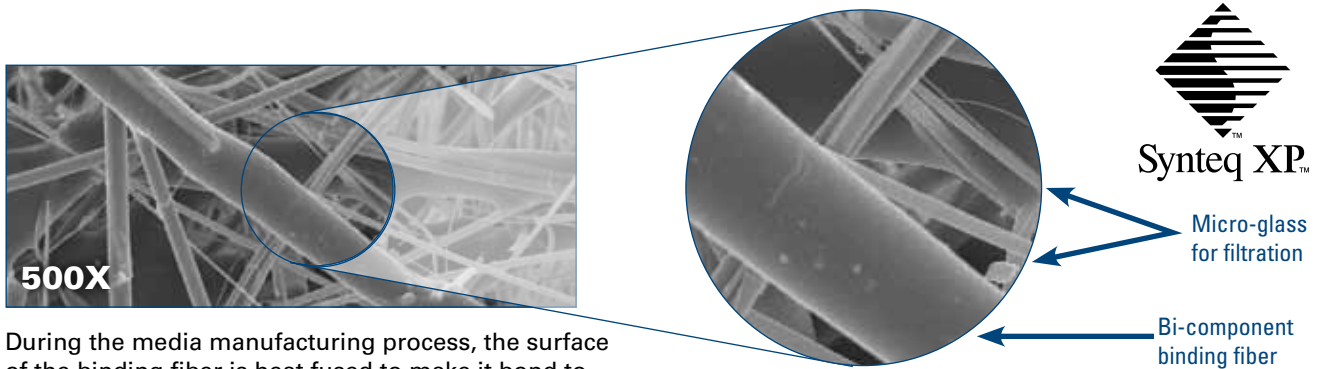

During the media manufacturing process, the surface of the binding fiber is heat fused to make it bond to the surrounding micro-glass – no resin webbing to block pores.

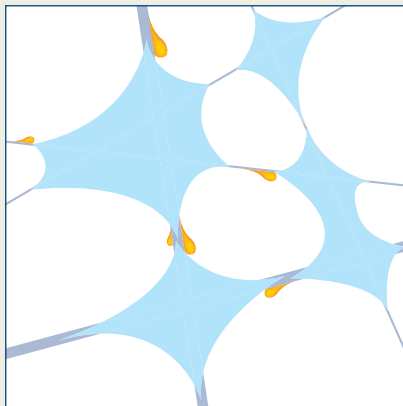

**TRADITIONAL MIST CARTRIDGE MEDIA (WITH RESINS)**

- Made with resins to bond fibers
- Resins reduce air pathways and block drainage

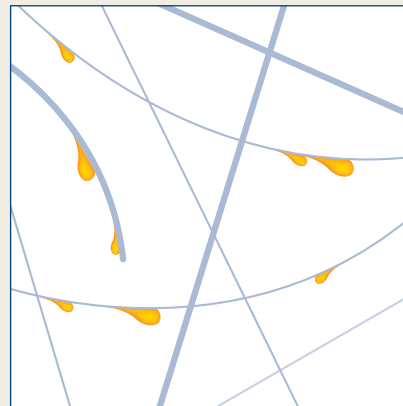

**TRADITIONAL MIST PANEL FILTER MEDIA (LOOSE FIBERS)**

- Four-layer media structure without fiber bonding
- Fibers sag under weight of oil
- Fiber movement creates larger holes that pass oil

SYSTEM CURVES FOR WSO

POWERFUL PERFORMANCE

Unlike other products that require upgrades for more demanding applications, each WSO comes standard with a unique high performance fan. The system curves below indicate available external static pressure to the unit with clean filters.

WSO 10\* (3/4 HP)

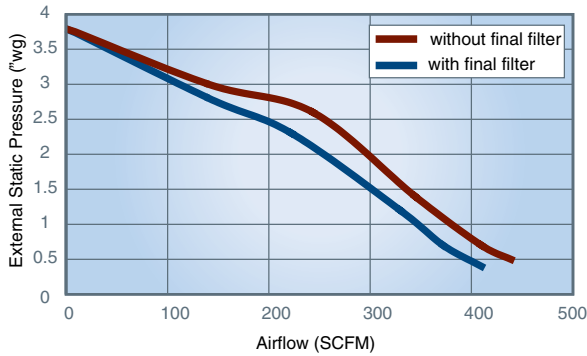

WSO 15\* (1-1/2 HP)

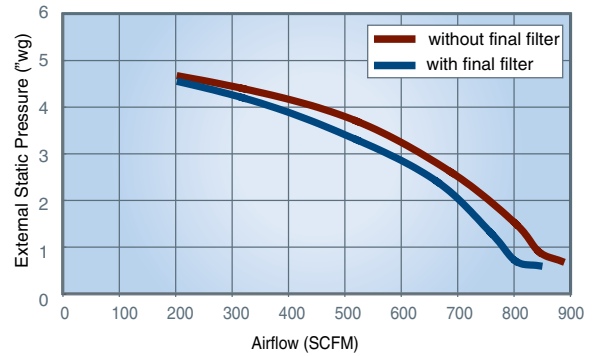

WSO 20\* (3 HP)

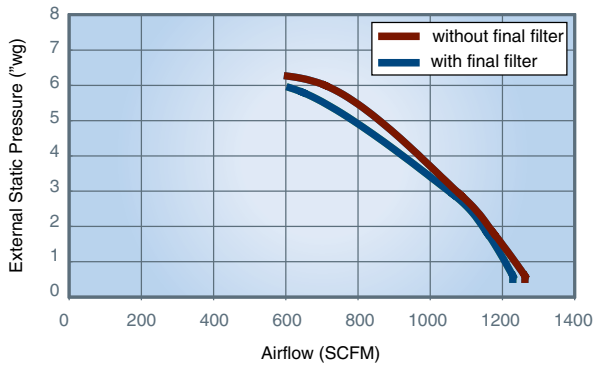

WSO 25-1\* (3 HP)

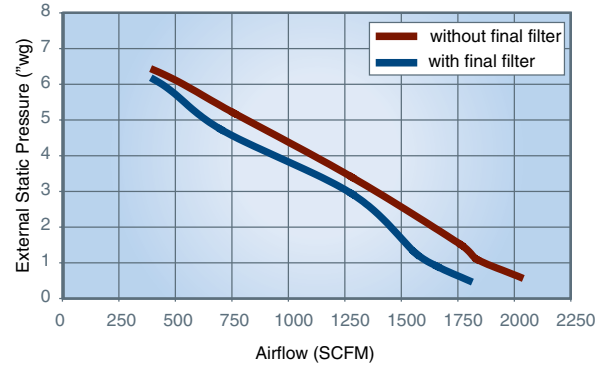

WSO 25-2 (7.5 HP)

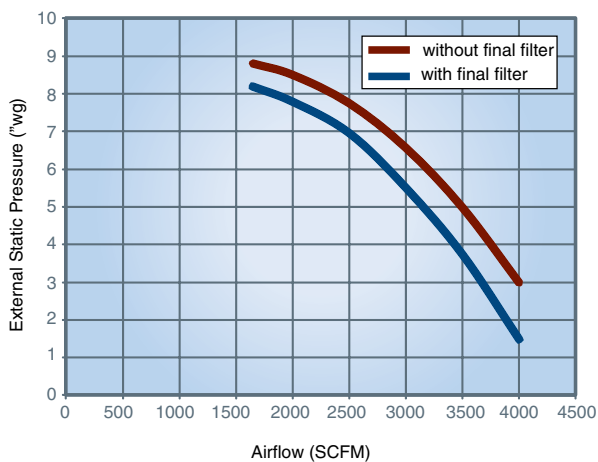

WSO 25-3 (10 HP)

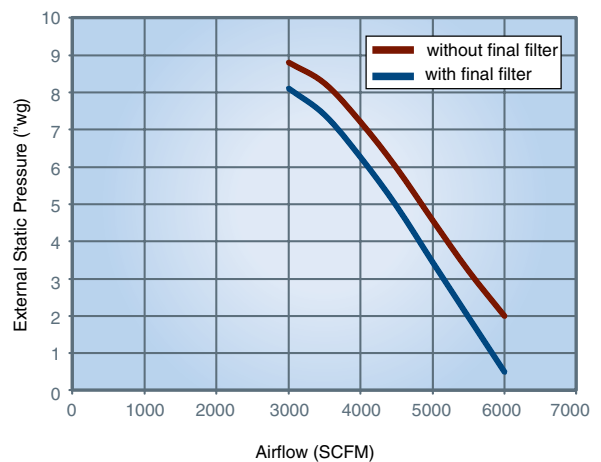

\* WSO 10, 15, 20, and 25-1 have integral power packs (motor and fan).

DIMENSIONS & SPECIFICATIONS

**WSO 10, 15, 20**  
Machine Mounted (MM)

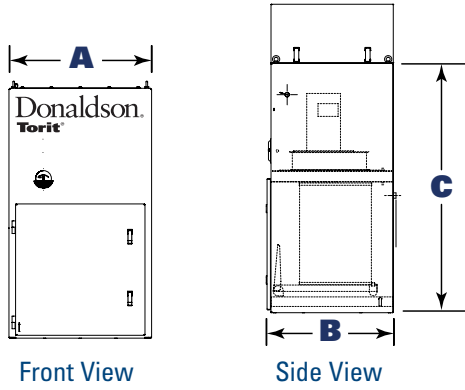

**WSO 25-2, 25-3**

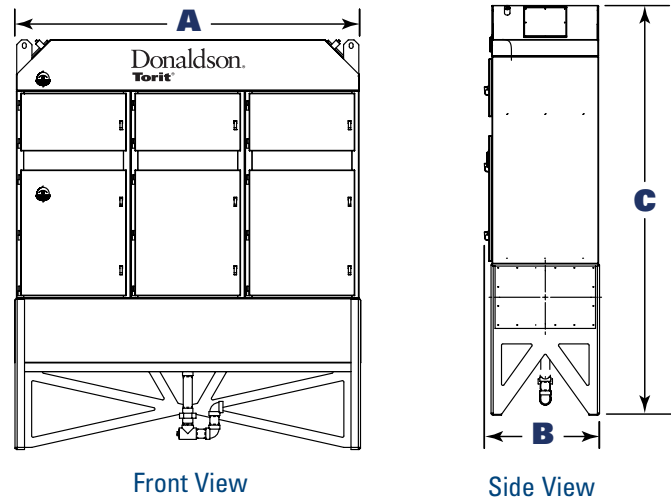

**WSO 20, 25-1**  
Floor Mounted (FM)

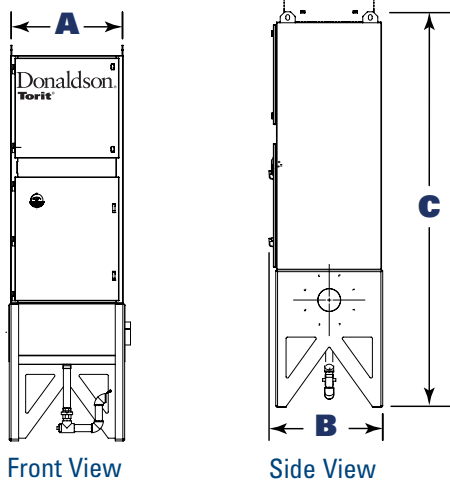

Models	Nominal Airflow* (cfm)	No. of Filters	Filter Height (in)	Filter Area			Motor (hp)	Shipping Weight (lbs)	Dimensions (inches)				Sound Level** dB(A)	
				Water (ft <sup>2</sup> )	Oil (ft <sup>2</sup> )	Smoke (ft <sup>2</sup> )			A	B	C without Afterfilter	C with Afterfilter	without Afterfilter	with Afterfilter
WSO 10	450	1	10	50	43	—	¾	180	19.0	20.9	33.2	36.5	66	63
WSO 15	850	1	15	125	109	85	1½	250	24.0	24.0	41.2	44.5	70	68
WSO 20	1230	1	20	167	146	113	3	285	28.0	26.0	49.1	60.6	68	70
WSO 20 (FM)	1230	1	20	167	146	113	3	385	28.0	26.0	85.2	96.6	68	70
WSO 25-1	1850	1	25	286	245	185	3	750	30.8	30.3	105.4	114.3	71	69
WSO 25-2	3700	2	25	572	480	390	†	1000	60.8	30.3	107.7	107.6	†	†
WSO 25-3	5550	3	25	858	735	585	†	1330	90.8	30.3	107.7	107.6	†	†

\* Based on clean filters.

\*\* Published dB(A) sound pressure levels were made in a hemi-anechoic chamber. Units were run with clean filters and maximum airflow through approximately 10 feet of ducting connected to an inlet plenum. Measurements were made 1.5 meters off the ground, 1 meter away from the collector, on the filter door side of the mist collector. Actual installed equipment sound pressure levels will vary depending upon the measurement location, the operating conditions, the installation, and the surrounding environment.

† Optional fans available. See optional fan specifications for sound level data.

## STANDARD FEATURES &amp; EQUIPMENT OPTIONS

Collector Design	WSO Models*					
	10, 15, 20		20, 25-1		25-2, 25-3	
	Std	Opt	Std	Opt	Std	Opt
Mild Steel Construction	X		X		X	
Inlet Hopper with Collar		X	X		X	
Inlet Hopper with Legs		X		X		X
Inlet Hopper with Vibration Isolators		X				
Integral Power Packs	X		X			
Machine Mount	X					
Ceiling Mount		X				
Floor Mount		X	X		X	
P-Trap Assembly		X		X		X
Drain Collection Container		X		X		
Flex-Duct		X				
<b>Filters</b>						
First-Stage Wire Mesh	X		X		X	
First-Stage Polypropylene Mesh		X		X		X
High Efficiency First-Stage		X		X		X
Synteq XP for Water Soluble	X		X		X	
Synteq XP for Straight Oil		X		X		X
Synteq XP for Smoke		X		X		X
Third-Stage HEPA Filter		X		X		X
Third-Stage 95% DOP Filter		X		X		X
<b>Paint System</b>						
Blue Powder Coat Finish Meets 350-hr. Salt Spray Corrosion Protection Test	X		X		X	
Custom Color		X		X		X
<b>Electrical Controls, Gauges &amp; Enclosures</b>						
Minihelic <sup>®</sup> *** Gauge	X					
Magnehelic <sup>®</sup> ** Gauge			X		X	
IEC Motor Starter		X		X		X
Type 12 (NEMA & UL) Motor Starter		X		X		X
Junction Box - Mounted & Prewired		X		X		
Remote Start/Stop		X		X		X
Machine Tool Interlock		X		X		X
Mounted and Prewired Motor Starters		X				
<b>Warranty</b>						
10-Year Warranty	X		X		X	

\* Custom size units larger than WSO 25-3 are also available.

\*\* Minihelic and Magnehelic are registered trademarks of Dwyer Instruments, Inc.

PROVEN PERFORMANCE ON HUNDREDS OF APPLICATIONS



**WSO**  
Oil mist  
20,000 cfm



**WSO**  
Horizontal grinder  
850 cfm



**WSO**  
Machining  
center  
1,200 cfm



**WSO**  
Cold forming  
1,200 cfm

## DONALDSON® TORIT® CLEARS THE SMOKE AT UNITED GEAR & ASSEMBLY

### The WSO Mist Collector dramatically reduces oily smoke

**INDUSTRY:** Machining

**PROBLEM:** Excessive smoke generated from hobbers during the gear production process

**SOLUTION:** Donaldson Torit WSO Mist Collector significantly reduced the amount of smoke in the plant, maintenance time, and cost

How many gear hobbers does it take to fill a 24,000 square foot room with smoke in less than 20 minutes? Just one.

United Gear & Assembly, Inc. (UGA) manufactures gears and shafts for motors, generators, transmissions and drive trains used by OEM manufacturers worldwide, including custom gear and shaft products designed to meet rigid specifications. The company's Hudson, Wisconsin manufacturing plant needed to reduce the amount of smoke generated from its hobbers during the gear production process.

Hobbing is a multipoint machining process in which gear teeth are progressively generated by a series of cuts with a helical cutting tool called a hob. Gear hobbing uses sulfuric oil, which generates a high degree of smoke. Dry hobbing, while cutting down on the amount of oil used, still generates excessive smoke when the gears are cleaned with compressed air.

"We run a lot of short jobs right now, which include 300 – 5,000 parts per month per machine," said Tom Huppert, in charge of maintenance at United Gear & Assembly, Inc. "The sulfuric oil used in our gear hobbers was generating too much smoke – our facility was filling up in just a few minutes. And while our dry hobbers use less oil, they also generated a lot of smoke. Our people were complaining, and we needed a way to stop it."

UGA installed its first Donaldson® Torit® WSO Mist Collector two years ago and achieved immediate success. The WSO provides filter solutions for the three mist categories: water-soluble coolants, straight oil, and the most challenging— oily smoke. It can be configured to meet specific facility requirement, including machine mount, stand mount for a single machine, and ducted cellular and central systems. "We mounted a WSO-15 right on our gear hobber and it did the trick," continued Huppert. "We had tried other collectors. They vibrated too loudly, their filters had to be changed too often – which added to our cost – or parts and service were not immediately available to us. The Donaldson WSOs have far met our expectations in all levels of performance."

The WSO uses revolutionary Synteq XP™ Media Technology, which blends small and large fibers with a proprietary, resin-free bonding system that provides high efficiency, low operating pressure and long filter life when compared to traditional filters. "The WSO mist collector has been running for two years and we've only had to change the filter once," said Huppert. "For the amount of smoke our hobbers generate, that's better than we expected. Both our maintenance time and cost have been significantly reduced, and our employees are no longer complaining about the smoke in our facility."

Today UGA has six Donaldson Torit WSO mist collectors and plans to add more.

“We mounted a WSO-15 right on our gear hobber and it did the trick, continued Huppert. We had tried other collectors. They vibrated too loudly, their filters had to be changed too often – which added to our cost – or parts and service were not immediately available to us. The Donaldson WSOs have far met our expectations in all levels of performance.”

Tom Huppert,  
United Gear & Assembly, Inc.



## GLOBAL SUPPORT



- Facilities in 37 countries
- 40 manufacturing plants and 14 distribution centers
- Sales offices worldwide

## LEADING TECHNOLOGY



- Over 1,000 engineers and scientists worldwide
- Broad range of innovative collectors and filters
- 100s of filter media formulations

## EXPERIENCE & SERVICE



- Technical expertise and support
- Ready-to-ship filters and parts within 24 hours
- 1,000,000+ dust, fume, and mist collectors installed



**Call Donaldson Torit  
to get Cleaner Air today  
800-365-1331  
donaldsontorit.com**